



IN-CHANNEL WINDOW VISORS

Assembly, Installation, Operation,
and Maintenance Instructions

DOCUMENT NUMBER	IC-06
INSTALL TIME	30-60 MINUTES

DEALER / INSTALLER	Provide a copy of these instructions to the end user of this product. These instructions provide important operating and safety information. Demonstrate the proper use of the product with the end user. Have the end user demonstrate that they understand the proper use of the product.
END USER	Read and follow all instructions included in this manual. Ask your Dealer/Installer for assistance if you do not understand the proper use of the product. Never remove any informational or warning labels from the product. Failure to follow these instructions can result in injury or death.

TOOLS REQUIRED (NOT INCLUDED)

MICROFIBER CLOTH

PACKAGE CONTENTS - 2 PIECE SET

ITEM	PART DESCRIPTION	QTY
1	FRONT DRIVER SIDE VISOR	1
2	FRONT PASSENGER SIDE VISOR	1
3	ALCOHOL PAD	2

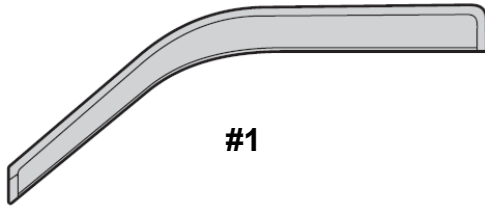

#1

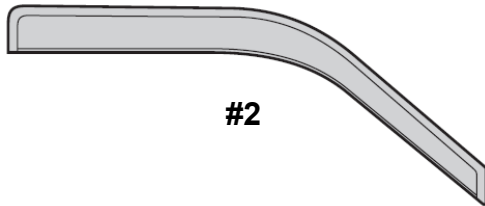

#2



#3

PACKAGE CONTENTS - 4 PIECE SET

ITEM	PART DESCRIPTION	QTY
1	FRONT DRIVER SIDE VISOR	1
2	FRONT PASSENGER SIDE VISOR	1
3	ALCOHOL PAD	2
4	REAR DRIVER SIDE VISOR	1
5	REAR PASSENGER SIDE VISOR	1

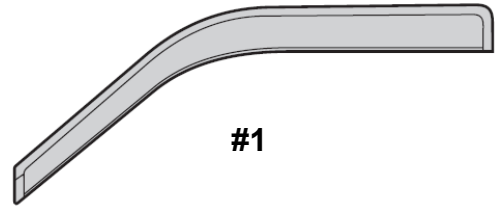

#1

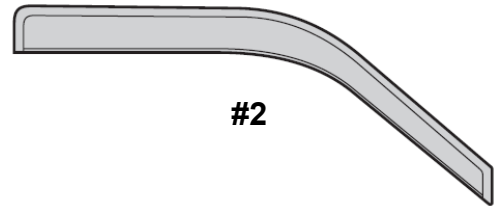

#2



#3



#4



#5

WARNINGS/SAFETY PRECAUTIONS



Before driving, ensure that the window visors are properly secured to the vehicle.
Avoid using cleaning solvents on the window visor surfaces.
Periodically check all window visors for proper adhesion.

PRIOR TO INSTALLATION:

Thoroughly clean and dry the installation area on the vehicle.
Verify contents of box.
Read instructions thoroughly.
Use caution to avoid scratching the window visors and vehicle.
Verify proper fitment of window visors to the vehicle.

INSTALLATION

1. Lower the window. Clean window channel with alcohol pad (#3). **(IMAGE 1)**
2. Remove tape liner from front and rear flanges of the front driver side visor (#1) if applicable. Peel back 2 inches of tape liner from each end of the top flange. **(IMAGE 2)**

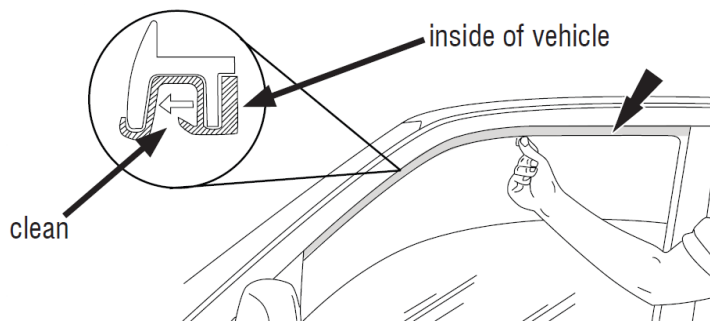

(IMAGE 1)

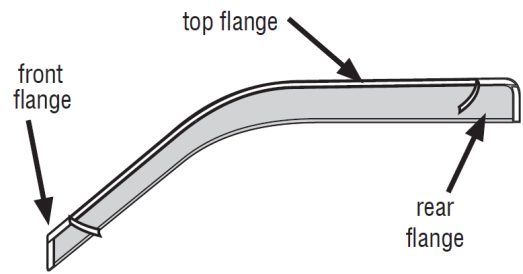

(IMAGE 2)

INSTALLATION (CONTINUED)

3. Slide the rear flange of the visor into position between the trim and frame. Then slide the top and front flanges into the window channel. **(IMAGE 3)**

4. With the visor in its final position remove the remainder of the tape liner. Apply pressure to the taped surfaces to secure in place. **(IMAGE 4)**

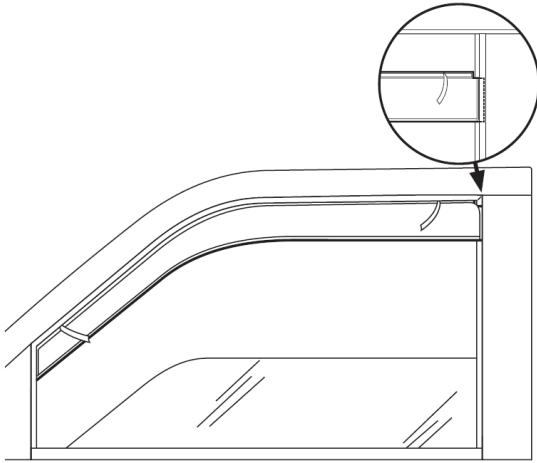

(IMAGE 3)

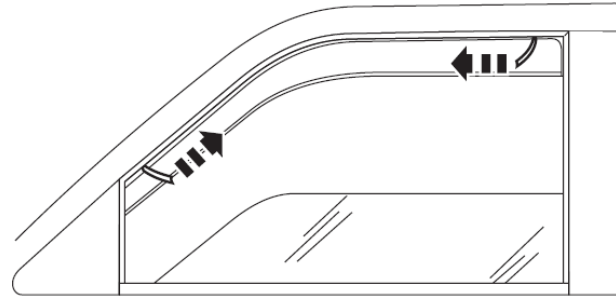

(IMAGE 4)

5. Roll up the window for at least 24 hours to maximize adhesion.

NOTE: It may be necessary to both hold the visor up into the window channel AND pull the bottom of the visor slightly outward while raising the glass to seat the visor properly. **(IMAGE 5)**

6. The rear driver side visor (#4) attaches using the same procedure as the front visor, if applicable. **(IMAGE 6)**

NOTE: The top flange of the rear visor slides into the window channel, the front flange fits between the rubber and window frame, and the rear flange attaches to the outside of the window post.

7. Repeat steps 1-6 for the front and rear passenger side visors (#2, #5) as applicable.

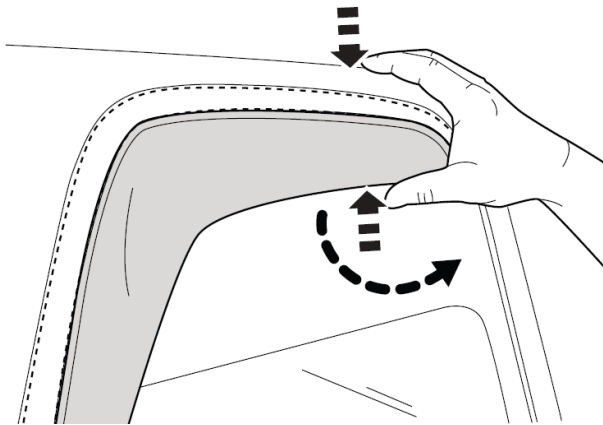

(IMAGE 5)

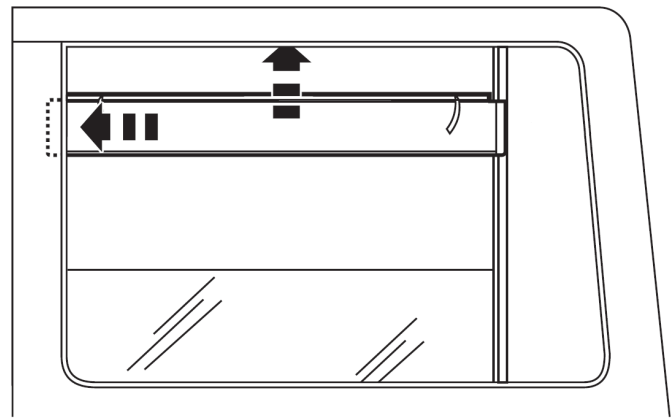

(IMAGE 6)

CLEANING

Wash window visors with mild soap and water. Dry with a clean microfiber cloth.

WARRANTY INFORMATION

Limited Lifetime Warranty:

Keystone Automotive Operations (KAO) warrants this product to be free of defects in material and workmanship at the time of purchase by the original retail consumer. KAO disclaims any other warranties, express or implied, including the warranty of fitness for a particular purpose or an intended use. If the product is found to be defective, KAO may replace or repair the product at our option, when the product is returned prepaid, with proof of purchase. Alteration to, improper installation, or misuse of this product voids the warranty. KAO's liability is limited to repair or replacement of products found to be defective, and specifically excludes liability for any incidental or consequential loss or damage.

This document is intended for use with the following part numbers. Note that this list may be incomplete:

4812IC

CONTACT US

WEBSITE: TrailFX.com

PHONE: 1-866-638-4870

EMAIL: support@trailfx.com